

SUITABLE FOR CHAINS:

- 828
- 880 / 880T / 880TA / 880M RG
- HFX880T
- 879 / 879T
- 878T
- EW878T / GW878T
- GD878T

MATERIALS

SPROCKETS: **PGF** REINFORCED POLYAMIDE

SCREWS: **SS** STAINLESS STEEL

NUTS: **B+NC** NICKEL PLATED BRASS

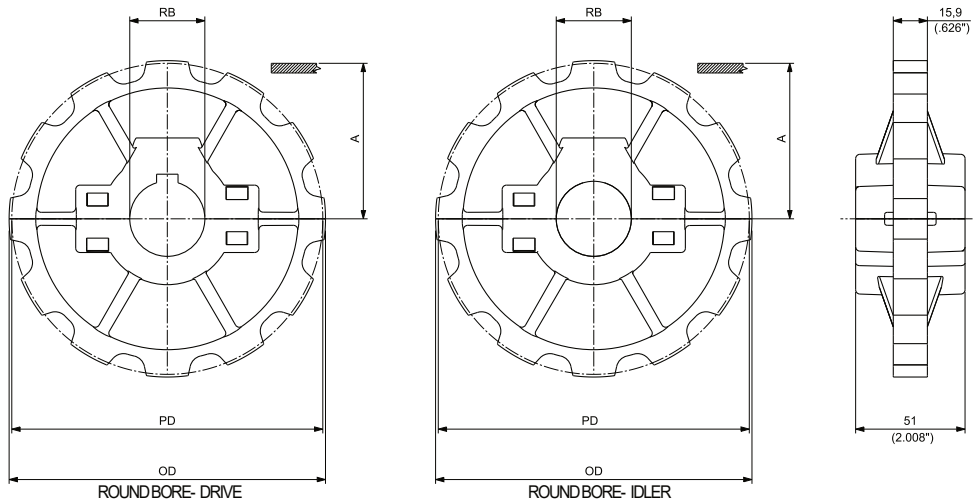

MOULDED SPLIT IDLERWHEELS FOR 880 / 880M RG/ 879 CHAINS
SEEPAGE 125



MOULDED SOLID IDLERWHEELS FOR 880 / 880M RG/ 879 CHAINS
SEEPAGE 124

MOULDED SPLIT DRIVE AND IDLER SPROCKETS

N. TEETH	PITCH DIAMETER PD		OUTSIDE DIAMETER OD		WEAR STRIP POSITIONING A		BORESIZE*		PART NUMBER ROUND BORE RB		WEIGHT	
	mm	inch	mm	inch	mm	inch	mm	inch**	DRIVE	IDLER	Kg	lbs
10	123,29	4.854	124,50	4.902	65,25	2.569	1	1	CMT028801001	CMT038801001	0,31	0.68
									CMT028801002	CMT038801002	0,30	0.66
									CMT028801003	CMT038801003	0,29	0.64
									CMT028801004	CMT038801004	0,28	0.62
									CMT028801006	CMT038801006	0,31	0.67
									CMT028801008	CMT038801008	0,30	0.65
									CMT028801011	CMT038801011	0,30	0.65
									CMT028801009	CMT038801009	0,29	0.64
									CMT028801010	CMT038801010	0,29	0.64
									CMT028801201	CMT038801201	0,42	0.93
12	147,21	5.796	147,30	5.799	77,21	3.040	1	1	CMT028801202	CMT038801202	0,41	0.91
									CMT028801203	CMT038801203	0,40	0.88
									CMT028801204	CMT038801204	0,39	0.86
									CMT028801205	CMT038801205	0,37	0.82
									CMT028801206	CMT038801206	0,41	0.91
									CMT028801208	CMT038801208	0,41	0.90
									CMT028801211	CMT038801211	0,40	0.88
									CMT028801209	CMT038801209	0,40	0.88
									CMT028801210	CMT038801210	0,39	0.87

*Diameter is indicated.

** Imperial round bore drive sprockets are supplied with setscrew. Metric round bore drive sprockets are supplied without setscrew.

SUITABLE FOR CHAINS:

- 828
- 880 / 880T / 880TA / 880M RG
- HFX880T
- 879 / 879T
- 878T

MATERIALS	
SPROCKETS:	PA POLYAMIDE
SCREWS:	SS STAINLESS STEEL
NUTS:	B BRASS

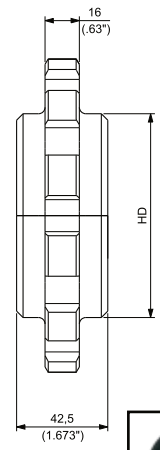
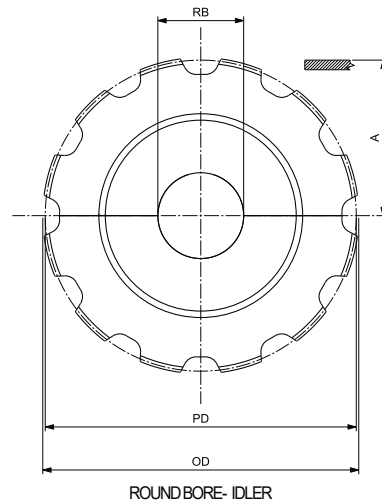
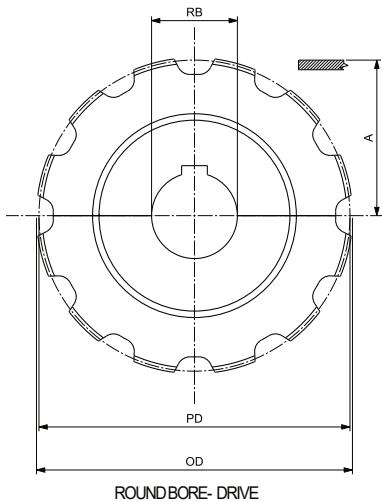

MACHINED SPLIT IDLERWHEELS FOR 880 / 880M RG / 879 CHAINS
SEE NEXT PAGE

MACHINED SPLIT DRIVE AND IDLER SPROCKETS

N. TEETH	PITCH DIAMETER PD		OUTSIDE DIAMETER OD		WEARSTRIP POSITIONING A		HD		BORESIZE*		PART NUMBER ROUND BORE RB		WEIGHT	
	mm	inch	mm	inch	mm	inch	mm	inch	mm	inch**	DRIVE	IDLER	Kg	lbs
9	111,40	4.386	109,80	4.323	59,30	2.335	75	2.95	25		CMAS028800925	CMAS038800925	0,30	0.66
									30		CMAS028800930	CMAS038800930	0,29	0.64
									35		CMAS028800935	CMAS038800935	0,28	0.61
									40		CMAS028800940	CMAS038800940	0,26	0.58
									1		CMAS0288009254	CMAS0388009254	0,30	0.66
									1 1/4		CMAS0288009317	CMAS0388009317	0,29	0.64
10	123,29	4.854	124,50	4.902	65,55	2.581	85	3.35	25		CMAS028801025	CMAS038801025	0,38	0.83
									30		CMAS028801030	CMAS038801030	0,37	0.81
									35		CMAS028801035	CMAS038801035	0,35	0.78
									40		CMAS028801040	CMAS038801040	0,34	0.75
									1		CMAS0288010254	CMAS0388010254	0,38	0.83
									1 1/4		CMAS0288010317	CMAS0388010317	0,37	0.81
11	135,24	5.324	134,90	5.311	71,22	2.804	90	3.54	25		CMAS028801125	CMAS038801125	0,43	0.95
									30		CMAS028801130	CMAS038801130	0,42	0.93
									35		CMAS028801135	CMAS038801135	0,41	0.90
									40		CMAS028801140	CMAS038801140	0,40	0.87
									1		CMAS0288011254	CMAS0388011254	0,43	0.95
									1 1/4		CMAS0288011317	CMAS0388011317	0,41	0.90
12	147,21	5.796	147,30	5.799	77,21	3.040	95	3.74	25		CMAS028801225	CMAS038801225	0,53	1.17
									30		CMAS028801230	CMAS038801230	0,52	1.14
									35		CMAS028801235	CMAS038801235	0,51	1.12
									40		CMAS028801240	CMAS038801240	0,49	1.09
									1		CMAS0288012254	CMAS0388012254	0,53	1.17
									1 1/4		CMAS0288012317	CMAS0388012317	0,51	1.12
		1 1/2		CMAS0288012381	CMAS0388012381	0,50	1.10							

*Diameter is indicated.

** Imperial round bore drive sprockets are supplied with setscrew. Metric round bore drive sprockets are supplied without setscrew.

SUITABLE FOR CHAINS:

- 915 / PHD915
- PHDG915
- 881
- 981 / 981M / PHD981M
- PHDG981M
- 820
- HFX820
- 831
- 828
- 880 / 880M RG
- 879

MATERIALS	
SPROCKETS:	PA POLYAMIDE
SCREWS:	SS STAINLESS STEEL
NUTS:	B BRASS



17T & 19T IDLERWHEELS

(for 21T, 23T & 25T seenext page)

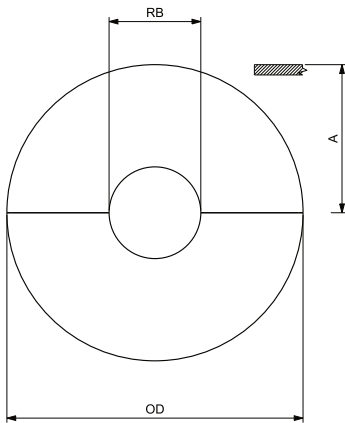

ROUND BORE- IDLER

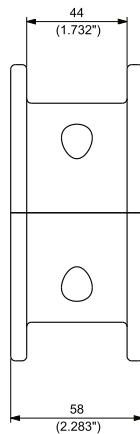

MACHINED SPLIT IDLERWHEELS

N. TEETH	OUTSIDE DIAMETER OD		WEARSTRIP POSITIONING A		BORESIZE*		PART NUMBER ROUND BORE RB IDLER	WEIGHT	
	mm	inch	mm	inch	mm	inch		Kg	lbs
17	106,50	4.193	53,25	2.096	25		CMAS048151725	0,34	0.76
					30		CMAS048151730	0,33	0.73
					35		CMAS048151735	0,31	0.69
					40		CMAS048151740	0,29	0.65
					1		CMAS0481517254	0,34	0.76
					1 ¼		CMAS0481517317	0,32	0.71
					1 ⅜		CMAS0481517349	0,32	0.71
					1 ⅞		CMAS0481517365	0,31	0.69
					1 1/2		CMAS0481517381	0,30	0.66
					19	118,00	4.646	59,00	2.323
30		CMAS048151930	0,44	0.97					
35		CMAS048151935	0,42	0.93					
40		CMAS048151940	0,40	0.89					
1		CMAS0481519254	0,45	1.00					
1 ¼		CMAS0481519317	0,42	0.92					
1 ⅜		CMAS0481519349	0,42	0.92					
1 ⅞		CMAS0481519365	0,40	0.89					
1 1/2		CMAS0481519381	0,38	0.84					

*Diameter isindicated.

SUITABLE FOR CHAINS:

- 880T / HFX880T / 880TA
- 879T
- 878T
- EW878T / GW878T / GD878T

MATERIALS

SPROCKETS:	PA	POLYAMIDE
SCREWS:	SS	STAINLESS STEEL
NUTS:	B	BRASS

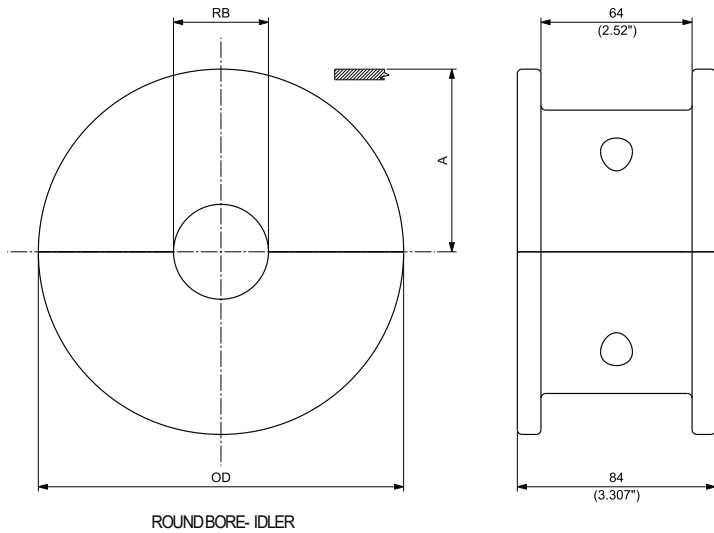

MACHINED SPLIT IDLER WHEELS

N. TEETH	OUTSIDE DIAMETER OD		WEARSTRIP POSITIONING A		BORESIZE*		PART NUMBER ROUND BORE RB IDLER	WEIGHT	
	mm	inch	mm	inch	mm	inch		Kg	lbs
9	118,00	4.646	59,00	2.323	25		CMAS04880T0925	0,64	1.41
					30		CMAS04880T0930	0,62	1.36
					35		CMAS04880T0935	0,59	1.31
					40		CMAS04880T0940	0,57	1.25
					1		CMAS04880T09254	0,64	1.41
					1 ¼		CMAS04880T09317	0,62	1.36
					1 1/2		CMAS04880T09381	0,59	1.31
10	129,80	5.110	64,90	2.555	25		CMAS04880T1025	0,82	1.80
					30		CMAS04880T1030	0,80	1.75
					35		CMAS04880T1035	0,77	1.70
					40		CMAS04880T1040	0,74	1.64
					1		CMAS04880T10254	0,82	1.80
					1 ¼		CMAS04880T10317	0,77	1.70
					1 1/2		CMAS04880T10381	0,75	1.66
11	142,30	5.602	71,15	2.801	25		CMAS04880T1125	1,02	2.25
					30		CMAS04880T1130	1,00	2.20
					35		CMAS04880T1135	0,98	2.15
					40		CMAS04880T1140	0,95	2.09
					1		CMAS04880T11254	1,02	2.25
					1 ¼		CMAS04880T11317	0,98	2.15
					1 1/2		CMAS04880T11381	0,96	2.11
12	154,70	6.091	77,35	3.045	25		CMAS04880T1225	1,24	2.74
					30		CMAS04880T1230	1,22	2.69
					35		CMAS04880T1235	1,20	2.64
					40		CMAS04880T1240	1,17	2.57
					1		CMAS04880T12254	1,24	2.73
					1 ¼		CMAS04880T12317	1,20	2.64
					1 1/2		CMAS04880T12381	1,18	2.60

*Diameter is indicated.

SUITABLE FOR CHAINS:

- 915 / PHD915
- PHDG915
- 881
- 981 / 981M / PHD981M
- PHDG981M
- 820
- HFX820
- 831
- 828
- 880 / 880M RG
- 879

MATERIALS

SPROCKETS: **PGF** REINFORCED POLYAMIDE

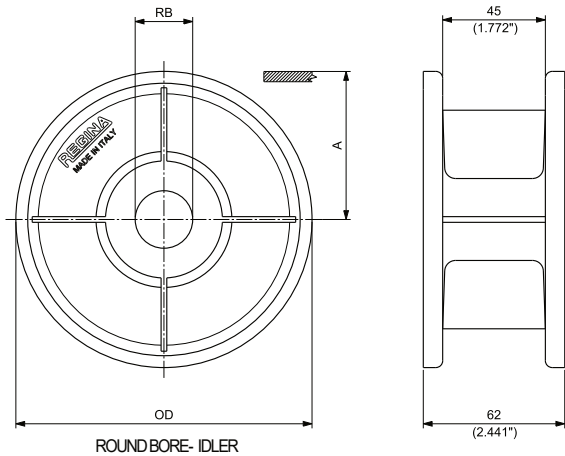

MOULDED SOLID IDLER WHEELS

N. TEETH	OUTSIDE DIAMETER OD		WEARSTRIP POSITIONING A		BORESIZE*		PART NUMBER ROUND BORE RB IDLER	WEIGHT	
	mm	inch	mm	inch	mm	inch		Kg	lbs
21	129,80	5.110	64,90	2.555	25		CMT032502101	0,22	0.48
					30		CMT032502102	0,22	0.49
					35		CMT032502103	0,22	0.49
					40		CMT032502104	0,20	0.44
					1		CMT032502106	0,22	0.49
					1 ¼		CMT032502108	0,21	0.47
					1 ⅜		CMT032502111	0,21	0.47
					1 ⅞		CMT032502109	0,20	0.44
					1 1/2		CMT032502110	0,22	0.49
					23	142,30	5.602	71,15	2.801
30		CMT032502302	0,25	0.55					
35		CMT032502303	0,24	0.53					
40		CMT032502304	0,24	0.54					
1		CMT032502306	0,24	0.54					
1 ¼		CMT032502308	0,24	0.53					
1 ⅜		CMT032502311	0,24	0.53					
1 ⅞		CMT032502309	0,24	0.53					
1 1/2		CMT032502310	0,25	0.55					
25	154,70	6.091	77,35	3.045					
					30		CMT032502502	0,30	0.66
					35		CMT032502503	0,29	0.64
					40		CMT032502504	0,28	0.62
					1		CMT032502506	0,30	0.65
					1 ¼		CMT032502508	0,29	0.64
					1 ⅜		CMT032502511	0,29	0.64
					1 ⅞		CMT032502509	0,29	0.64
					1 1/2		CMT032502510	0,28	0.61

*Diameter is indicated.

SUITABLE FOR CHAINS:

- 915 / PHD915
- PHDG915
- 881
- 981 / 981M / PHD981M
- PHDG981M
- 820
- HFX820
- 831

MATERIALS

SPROCKETS: **PGF** REINFORCED POLYAMIDE

SCREWS: **SS** STAINLESS STEEL

NUTS: **S+ZN** ZINC PLATED STEEL

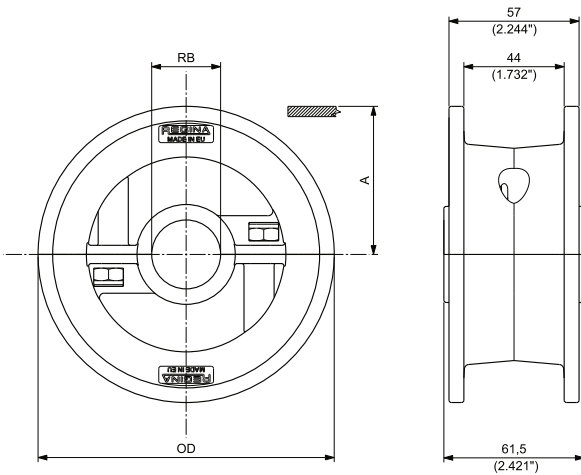

ROUNDBORE- IDLER

MOULDED SPLIT IDLER WHEELS

N. TEETH	OUTSIDE DIAMETER OD		WEAR STRIP POSITIONING A		BORESIZE*		PART NUMBER ROUND BORE RB IDLER	WEIGHT	
	mm	inch	mm	inch	mm	inch		Kg	lbs
21	129,80	5.110	64,90	2.555	25		CMTS048152125	0,33	0.72
					30		CMTS048152130	0,33	0.73
					35		CMTS048152135	0,31	0.68
					40		CMTS048152140	0,34	0.76
					45		CMTS048152145	0,31	0.69
					1		CMTS0481521254	0,33	0.72
					1 ¼		CMTS0481521317	0,32	0.71
23	142,30	5.602	71,15	2.801	25		CMTS048152325	0,36	0.80
					30		CMTS048152330	0,37	0.81
					35		CMTS048152335	0,35	0.76
					40		CMTS048152340	0,38	0.84
					45		CMTS048152345	0,35	0.77
					1		CMTS0481523254	0,36	0.80
					1 ¼		CMTS0481523317	0,36	0.79
25	154,70	6.091	77,35	3.045	25		CMTS048152525	0,40	0.89
					30		CMTS048152530	0,41	0.90
					35		CMTS048152535	0,39	0.85
					40		CMTS048152540	0,42	0.92
					45		CMTS048152545	0,39	0.86
					1		CMTS0481525254	0,40	0.89
					1 ¼		CMTS0481525317	0,40	0.88

*Diameter is indicated.