

SUITABLE FOR CHAINS:

- 8257
- HFX8257
- LBP8257
- 882 / 882T / 882M
- HFX882T / HFX882M
- LBP882T / LBP882M

MATERIALS

SPROCKETS: **PGF** REINFORCEDPOLYAMIDE

SCREWS: **SS** STAINLESS STEEL

NUTS: **B+NC** NICKEL PLATED BRASS

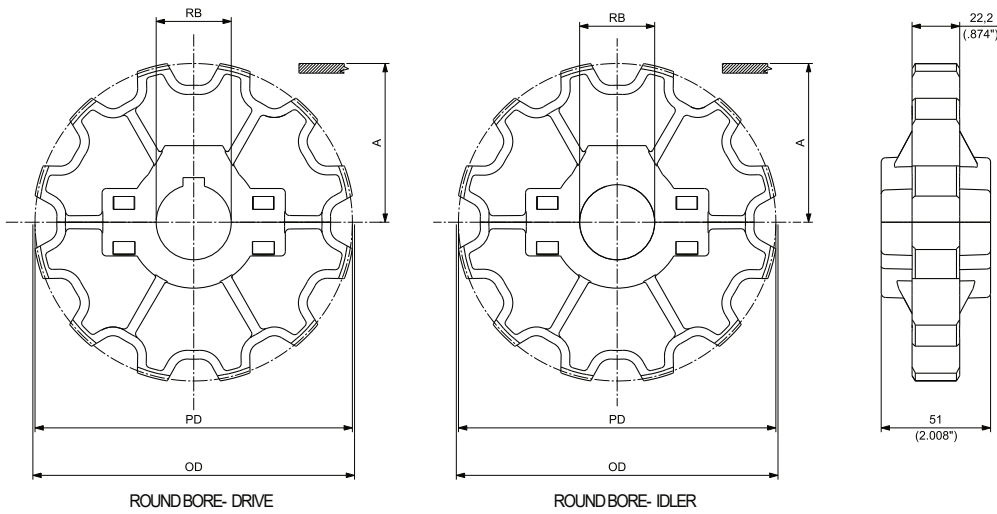

MOULDED SPLIT DRIVE AND IDLER SPROCKETS

N. TEETH	PITCH DIAMETER PD		OUTSIDE DIAMETER OD		WEAR STRIP POSITIONING A		BORESIZE*		PART NUMBER ROUND BORE RB		WEIGHT	
	mm	inch	mm	inch	mm	inch	mm	inch**	DRIVE	IDLER	Kg	lbs
10	123,29	4.854	124,50	4.902	66,35	2.612	25		CMT028821001	CMT038821001	0,30	0.65
							30		CMT028821002	CMT038821002	0,29	0.64
							35		CMT028821003	CMT038821003	0,28	0.62
							40		CMT028821004	CMT038821004	0,27	0.60
							1		CMT028821006	CMT038821006	0,30	0.65
							1 ¼		CMT028821008	CMT038821008	0,30	0.65
							1 ⅜		CMT028821011	CMT038821011	0,29	0.64
							1 ⅞		CMT028821009	CMT038821009	0,28	0.62
							1 1/2		CMT028821010	CMT038821010	0,27	0.60
							12	147,21	5.796	150,00	5.906	78,31
30		CMT028821202	CMT038821202	0,39	0.86							
35		CMT028821203	CMT038821203	0,38	0.83							
40		CMT028821204	CMT038821204	0,37	0.81							
45		CMT028821205	CMT038821205	0,35	0.78							
1		CMT028821206	CMT038821206	0,39	0.86							
1 ¼		CMT028821208	CMT038821208	0,39	0.85							
1 ⅜		CMT028821211	CMT038821211	0,38	0.83							
1 ⅞		CMT028821209	CMT038821209	0,37	0.81							
1 1/2		CMT028821210	CMT038821210	0,35	0.78							

*Diameter isindicated.

** Imperial round bore drive sprocketsare supplied with setscrew.Metric round bore drive sprocketsare supplied without setscrew.

SUITABLE FOR CHAINS:

- 8257
- HFX8257
- LBP8257
- 882 / 882T / 882M

MATERIALS

SPROCKETS: **PA** POLYAMIDE

SCREWS: **SS** STAINLESS STEEL

NUTS: **B** BRASS

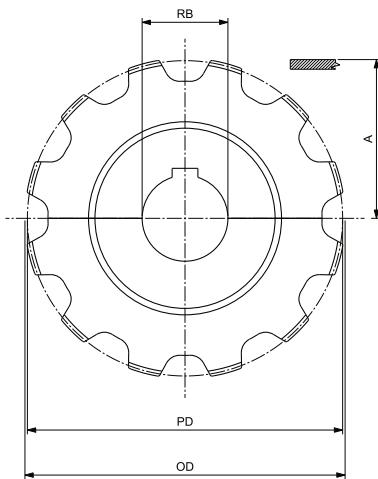

ROUND BORE- DRIVE

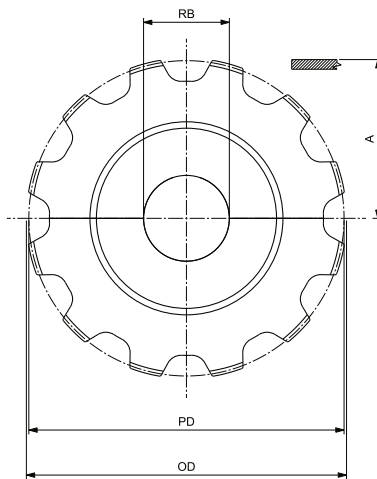

ROUND BORE- IDLER

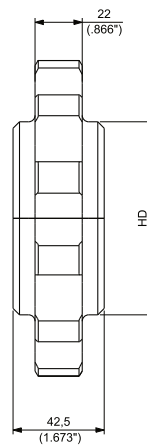

MACHINED SPLIT DRIVE AND IDLER SPROCKETS

N. TEETH	PITCH DIAMETER PD		OUTSIDE DIAMETER OD		WEARSTRIP POSITIONING A		HD		BORE SIZE*		PART NUMBER ROUND BORE RB		WEIGHT	
	mm	inch	mm	inch	mm	inch	mm	inch	mm	inch**	DRIVE	IDLER	Kg	lbs
9	111,40	4.386	109,80	4.323	60,40	2.378	60	2.36	25		CMAS028820925	CMAS038820925	0,28	0.62
									30		CMAS028820930	CMAS038820930	0,27	0.60
									35		CMAS028820935	CMAS038820935	0,26	0.57
									40		CMAS028820940	CMAS038820940	0,25	0.54
									1		CMAS0288209254	CMAS0388209254	0,28	0.62
									1 ¼		CMAS0288209317	CMAS0388209317	0,27	0.59
10	123,29	4.878	122,40	4.819	66,65	2.624	75	2.95	25		CMAS028821025	CMAS038821025	0,37	0.82
									30		CMAS028821030	CMAS038821030	0,36	0.80
									35		CMAS028821035	CMAS038821035	0,35	0.77
									40		CMAS028821040	CMAS038821040	0,34	0.74
									1		CMAS0288210254	CMAS0388210254	0,37	0.82
									1 ¼		CMAS0288210317	CMAS0388210317	0,35	0.76
11	135,24	5.324	134,90	5.311	72,32	2.874	85	3.35	25		CMAS028821125	CMAS038821125	0,45	1.00
									30		CMAS028821130	CMAS038821130	0,44	0.98
									35		CMAS028821135	CMAS038821135	0,43	0.95
									40		CMAS028821140	CMAS038821140	0,42	0.92
									1		CMAS0288211254	CMAS0388211254	0,45	1.00
									1 ¼		CMAS0288211317	CMAS0388211317	0,43	0.95
12	147,21	5.796	147,30	5.799	78,31	3.083	90	3.54	25		CMAS028821225	CMAS038821225	0,56	1.24
									30		CMAS028821230	CMAS038821230	0,55	1.21
									35		CMAS028821235	CMAS038821235	0,54	1.18
									40		CMAS028821240	CMAS038821240	0,52	1.15
									1		CMAS0288212254	CMAS0388212254	0,56	1.23
									1 ¼		CMAS0288212317	CMAS0388212317	0,54	1.18
		CMAS0288212381	CMAS0388212381	0,53	1.17									

*Diameter is indicated.

** Imperial round bore drive sprockets are supplied with setscrew. Metric round bore drive sprockets are supplied without setscrew.

SUITABLE FOR CHAINS:

- 882T
- HFX 882T
- LBP882T

MATERIALS

SPROCKETS:	PA	POLYAMIDE
SCREWS:	SS	STAINLESS STEEL
NUTS:	B	BRASS

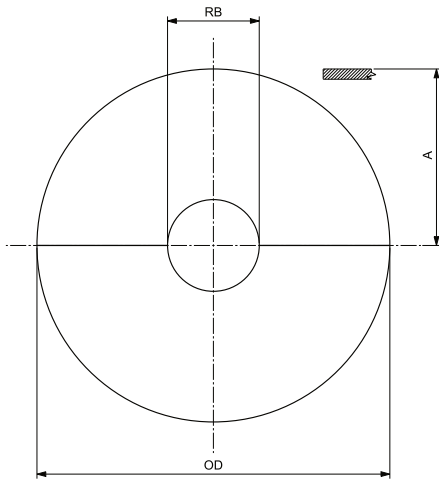

ROUND BORE- IDLER

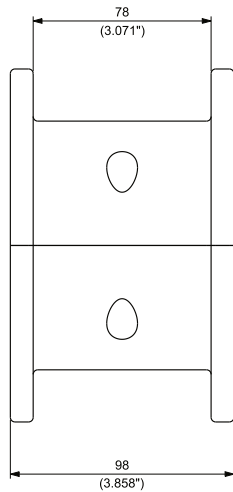

MACHINED SPLIT IDLERWHEELS

N. TEETH	OUTSIDE DIAMETER OD		WEARSTRIP POSITIONING A		BORESIZE*		PART NUMBER ROUND BORE RB IDLER	WEIGHT	
	mm	inch	mm	inch	mm	inch		Kg	lbs
9	118,00	4.646	59,00	2.323	25		CMAS04882T0925	0,59	1.30
					30		CMAS04882T0930	0,57	1.25
					35		CMAS04882T0935	0,54	1.18
					40		CMAS04882T0940	0,50	1.11
					1		CMAS04882T09254	0,59	1.30
					1 ¼		CMAS04882T09317	0,56	1.23
					1 1/2		CMAS04882T09381	0,52	1.14
10	129,80	5.110	64,90	2.555	25		CMAS04882T1025	0,79	1.74
					30		CMAS04882T1030	0,76	1.67
					35		CMAS04882T1045	0,73	1.60
					40		CMAS04882T1040	0,69	1.53
					1		CMAS04882T10254	0,78	1.72
					1 ¼		CMAS04882T10317	0,72	1.58
					1 1/2		CMAS04882T10381	0,62	1.37
11	142,30	5.602	71,15	2.801	25		CMAS04882T1125	0,98	2.17
					30		CMAS04882T1130	0,96	2.12
					35		CMAS04882T1135	0,93	2.05
					40		CMAS04882T1140	0,90	1.98
					1		CMAS04882T11254	0,98	2.17
					1 ¼		CMAS04882T11317	0,93	2.05
					1 1/2		CMAS04882T11381	0,91	2.01
12	154,70	6.091	77,35	3.045	25		CMAS04882T1225	1,24	2.74
					30		CMAS04882T1230	1,22	2.69
					35		CMAS04882T1235	1,19	2.62
					40		CMAS04882T1240	1,16	2.55
					1		CMAS04882T12254	1,24	2.74
					1 ¼		CMAS04882T12317	1,19	2.62
					1 1/2		CMAS04882T12381	1,17	2.58

*Diameter is indicated.